



- Liquid temperature: 0 - 40°C/32 - 104°F
- HP range: 2 - 10HP / 1.5 - 7.5 KW
- PH: 6 - 8
- Rated Speed: 2900 rpm
- Protection calss: IP68
- Maximum depth: 8M

Features

1. High head high pass solid: semi-open impeller design enhance the pass solid.
2. Elbow shaped pump casing design.
3. Power cable export insulation treatment: increase waterproof and convenient to replace

Applications

1. Basement sewage discharge
2. Irrigation for Orchards
3. Irrigation for mountain slopes
4. Deep well water transport
5. High-lift water transport



KHL - 20



KHL - 30



USE FOR 380V

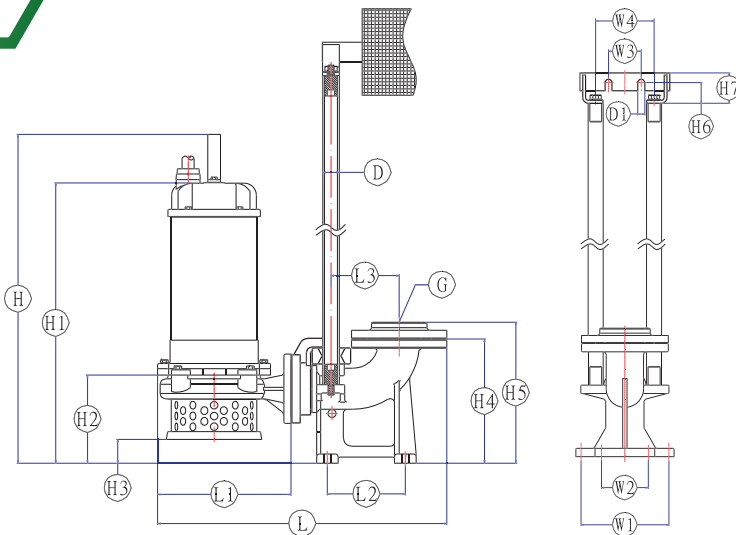
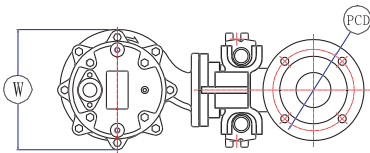

Dimension

Model	L	L1	L2	L3	W	W1	W2	W3	W4	H	H1	H2	H3	H4	H5	H6	H7	D	D1	PCD	G	
	mm	mm	mm	mm	mm	mm	mm	mm	mm	mm	mm	mm	mm	mm	mm	mm	mm	mm	mm	mm	mm	inch
KHL-20-1	548	244	152	133	208	100	188	70	125	642	558	168	51	242	275	44	65	32	15	150	2	
KHL-20-3	548	244	152	133	208	100	188	70	125	642	558	168	51	242	275	44	65	32	15	150	2	
KHL-30	564	260	152	133	222	100	188	70	125	641	547	172	46	242	275	44	65	32	15	150	2	
KHL-50	564	260	152	133	222	100	188	70	125	641	547	172	46	242	275	44	65	32	15	150	3	
KHL-75	687	297	230	202	255	252	252	70	125	780	681	250	69	346	366	44	65	32	15	170	3	
KHL-100	687	297	230	202	255	252	252	70	125	825	726	250	69	346	366	44	65	32	15	170	3	

Sectional View

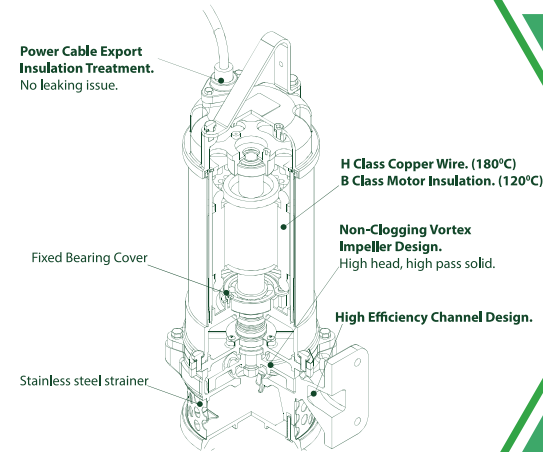

Standard Accessories

Model No.	Accessories	Pedestal Type
KHL-20	Elbow - Flange	TOS-S2
KHL-30	Elbow - Flange	TOS-S2
KHL-50	Elbow - Flange	TOS-S2
KHL-75	Elbow - Flange	TOS-L3
KHL-100	Elbow - Flange	TOS-L4

Curve

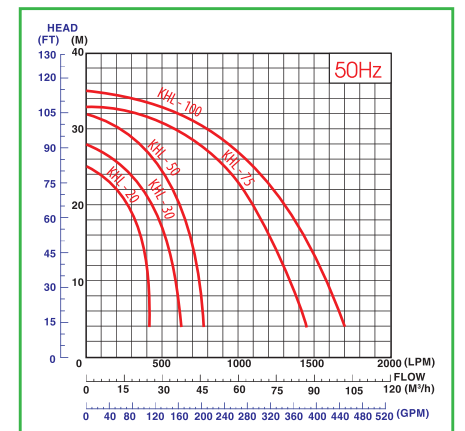

Specification

Model No.	Output		Outlet		Pass Solid (mm)	Max Flow (LPM)	LPM Flow @ Head					Max Head(M)	Weight (Kg)
	HP	KW	mm	inch			10M	15M	20M	25M	30M		
KHL-20	2	1.5	50	2"	12	415	400	370	260	-	-	25	35
KHL-30	3	2.2	50	2"	12	620	600	540	430	215	-	28	45
KHL-50	5	3.7	50	2"	15	770	750	710	620	470	220	32	50
KHL-75	7.5	5.5	80	3"	15	1450	1340	1230	1100	910	580	33	96
KHL-100	10	7.5	100	4"	15	1700	1580	1450	1300	1100	790	35	104

Construction

No	Name	Material
1	Motor casing	SUS304
2	Pump casing	FC25
3	Upper cover	FC20
4	Bearing upper cover	FC20
5	Impeller	BRASS
6	Seal cover	FC20
7	Diffuser	FC20
8	Flange	FC20
9	Handle	SUS410
10	Stator	SILICON STEEL
11	Rotor & shaft	SUS410
12	Capacitor	PP
13	Upper bearing	CNM5K
13-1	Lower bearing	CNM5K
14	Strainer	SUS304/FC20
15	Cable gland	NBR
16	Discharge adapter	ABS
17	Mechanical seal	**CA/ CE+CA/CE
18	Oil seal	NBR
18-1	Oil seal	NBR
19	Packing	NBR
19-1	Packing	NBR

